

Stainless steel- incremental encoder with hollow shaft

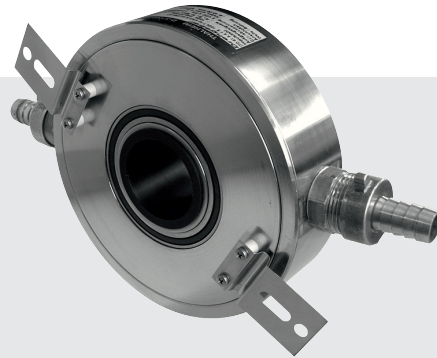

Features

- Incremental encoder with hollow shaft going through in stainless steel-version
- Number of pulses up to 4096 pulses/rev.
- Hollow shaft diameter up to Ø45 mm
- Water cooled over screw connections
- Mounting at torque support, mounting punch circle Ø190 mm
- TTL- or HTL- output signals
- Cable outlet radial
- electric isolated mounting

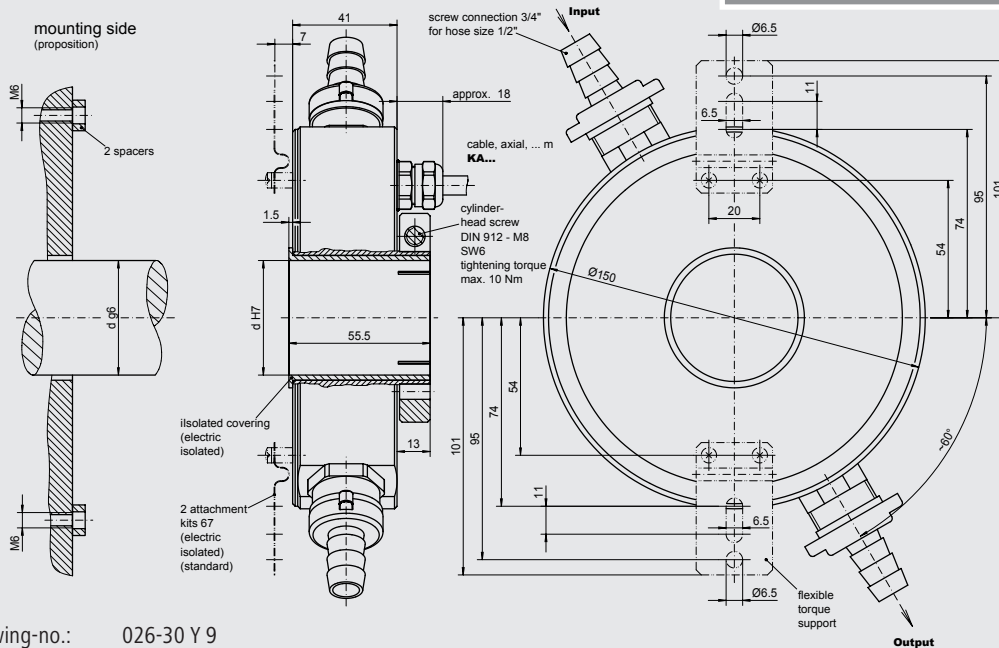

drawing-no.: 026-30 Y 9

Mechanical data

Design	A 4	A 4
Attachment kit	67	standard, (ref. data sheet »Attachment kit's«) 67
Housing	stainless steel	
Protection	IP 54	according to DIN EN 60 529 IP54
Construction principle	LED with glass slot disc	
max. revolution (mechanical)	$n_{max} \leq 4000 \text{ min}^{-1}$	(observe limit frequency)
Permissible motor-shaft play	axial $\leq 0.5 \text{ mm}$ radial $\leq 0.1 \text{ mm}$	
Vibration	55... 2000 Hz $\leq 100 \text{ m/s}^2$	according to DIN IEC 60 068, part 2 - 6
Shock	11 ms $\leq 300 \text{ m/s}^2$	according to DIN IEC 60 068, part 2 - 27
Hollow shaft diameter	d 40 mm	(standard), 30 mm, 35 mm, 45 mm possible 40
Weight	approx. 3770 g	

Electrical data

Number of pulses	Z	1024, 2048, 2500, 4096 pulses/rev.	XXXX
Electronic version (output signals)	TTL	Line driver-output stage, supply voltage: $U_B = 5 \text{ VDC} \pm 5\%$ (polarity protected), output amplitude: $U_{LOW} \leq 0.5 \text{ V}$, $U_{HIGH} \geq 2.5 \text{ V}$	T
	HTL	Push pull-output stage (short-circuit proof), supply voltage: $U_B = 8 - 30 \text{ VDC}$ (polarity protected), output amplitude: $U_{LOW} \leq 1.5 \text{ V}$, $U_{HIGH} \geq U_B - 3 \text{ V}$	H
Output signals	A, B, N + Inv.	2 square wave pulse trains, electr. phase shifted 90° + zero pulse, electr. length 90° + signal inverting	NI
Limit frequency	f_G	TTL 300 kHz HTL 160 kHz	
Output load current	I_{Load}	TTL $\leq 70 \text{ mA}$ HTL $\leq 70 \text{ mA}$	
Current consumption (no-load)	I_{max}	$\leq 100 \text{ mA}$	
Permissible cable length		$\leq 100 \text{ m}$ (Baumer Thalheim cable)	
Type of connection		cable, axial, 1.0 m (standard length)	KA1
Operating temperature range		0°C to $+100^\circ \text{C}$ (up to $+150^\circ \text{C}$ during shielded cable and water cooling)	E
Permissible relative humidity		$\leq 90\%$ (condensation not permitted)	

Options

Electronic version		TTL-output signals, line driver-output stage supply voltage: $U_B = 8 - 30 \text{ VDC}$ (polarity protected)	R
Type of connection	connector	performed at cable (ref. data sheet »Type of performed cables«)	...

Connection table

wire color	signals
brown	A
green	A inv.
grey	B
pink	B inv.
red	N
black	N inv.
brown 0.5 mm^2	$+U_B$
white 0.5 mm^2	0 V
blue	$+U_{Sensor}$
white	0 V_{Sensor}
transparent	shielding/housing

Output signal diagram

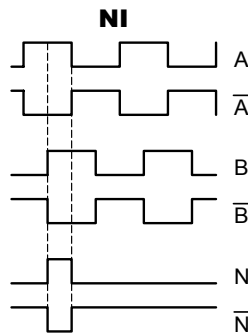

Pulse trains:
Clockwise rotation when looking at the end of the shaft (mounting side).

Ordering example:

ITD 61 Incremental encoder ITD 61	A 4 Design A 4	Y 9 Mechanical variant Y 9 = look at the drawing	1024 Number of pulses 1024 pulses/revolution	H Electronic version $U_B = 8 - 30 \text{ VDC HTL}$	NI Output signals A-, B-, N- track + inv.	KA1 Type of connection cable, axial, 1 m	E Operating temperature range 0°C to $+100^\circ \text{C}$	40 Hollow shaft diameter 40 mm	IP54 Protection IP54	67 Attachment kit variant 67
--	-----------------------------	---	---	--	--	---	--	---	-----------------------------------	---

Baumer Thalheim GmbH & Co. KG

Hessenring 17, D-37269 Eschwege, Germany

Phone: +49 (0)5651 9239-0 · Fax: +49 (0)5651 9239-80 · www.baumerthalheim.com